

# 2015 Transit Connect Mobility Van

The All-New Transit Connect from Ford

Now Roomier and more stylish than ever before

Fits a single wheelchair plus Five Passengers—no need to flip seats

*The Transit Connect mobility van brings the comfort and efficiency of a car with the durability of a Ford Truck*

## FEATURES

- ADA and FMVSS compliant
- Ideal for nursing homes, group homes, senior living and more
- Holds up to five passengers plus one wheelchair
- Exclusive Flex-Flat Ramp comes Standard. Folds flat to create usable deck when not in use. Details on back.
- Auto-retracting wheelchair securement system (electronic system available)
- Rear liftgate swings up and out of the way, plus provides coverage in inclement weather
- Best-in-Class 24 MPG average in combined driving
- Best-in-Class interior space
- Front and side-impact airbags for driver and front passenger
- Successfully crash tested

Built by TransitWorks—Akron, Ohio



Call Jarrod Runnels 409-895-3858

email: [fleetsales@outlook.com](mailto:fleetsales@outlook.com)

1211 US HWY 96 N, Silsbee, TX

[www.SilsbeeFleet.com](http://www.SilsbeeFleet.com)

SILSBEE  
**FLEET GROUP**



# Vehicle Layout & Specs

— Top View —

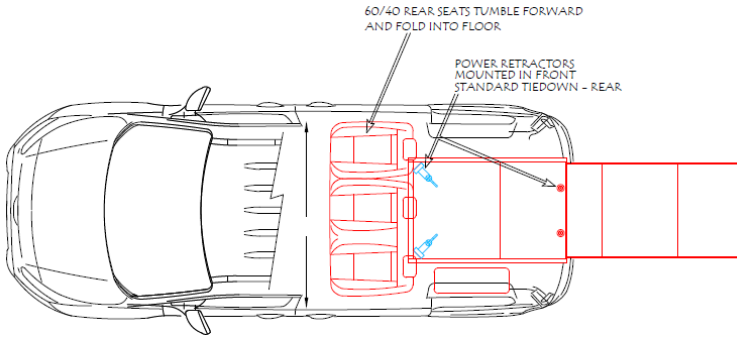

— Side View —

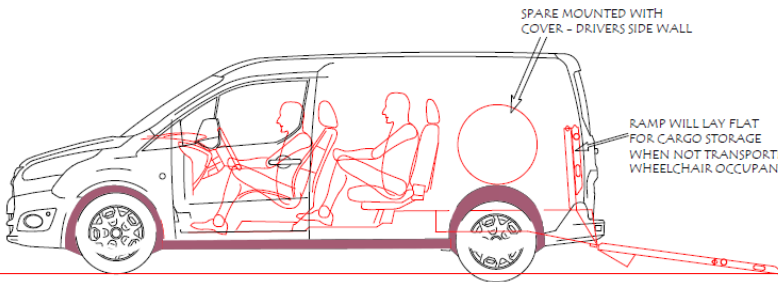

## VEHICLE SPECIFICATIONS CHART

Rear door opening height	58-1/2"
Rear door opening width	52"
Interior height (mid-section)	56-1/2"
Max. interior width @ at B-pillar	58-1/2"
Lowered floor length	51"
Width between wheelbox	48"
Ramp width	31-1/2"
Ramp length	58-1/2"
Ramp capacity	600 lbs.
Ramp angle	9 degrees
Wheelbase	120.6"

## FlexFlat Wheelchair Ramp—Standard

Before—Vertical



After—Flat



## FLEX FLAT

A wheelchair ramp that folds flat when not in use. It's there when you need it, and folds out of the way when you don't!

Creates a usable deck like a standard minivan perfect for luggage, boxes, cargo, golf clubs and more.

### No More Barriers!

- Like having both regular and accessible vans in one
- Converts in just seconds!



*Innovative. Incredibly Useful. Like having two vehicles in one.*

Call Jarrod Runnels 409-895-3858

email: [fleetsales@outlook.com](mailto:fleetsales@outlook.com)  
1211 US HWY 96 N, Silsbee, TX

[www.SilsbeeFleet.com](http://www.SilsbeeFleet.com)

SILSBEE  
**FLEET GROUP**

